

# Having a Pre-sales Building Survey on a beautiful Tudor property

## Independent Building Surveyors

If you are in the process of purchasing or selling a Tudor property 1stAssociated.co.uk can provide help and advice with regard to pre-sale building surveys, structural surveys, home buyers reports, independent valuations, property surveys, engineers reports, structural reports, specific defects report or any other property matters.

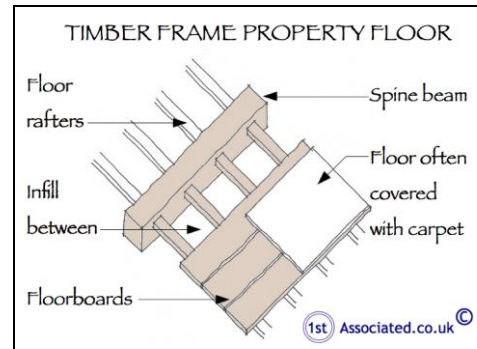

Timber frame floor

## We are experienced in surveying historic properties and listed properties

Unlike many Surveyors we are experienced in dealing with historic, Listed Buildings and properties within conservation areas. We like to meet you at the property during the survey to explain anything that you do not understand regarding the property and its characteristics. We are also more than happy to talk to you afterwards about the report. Please free phone 0800 298 5424 for a friendly chat with one of our surveyors.

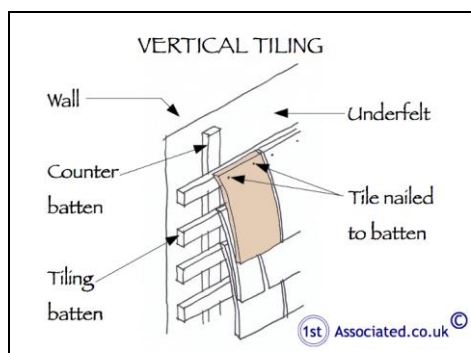

Vertical tiling



Traditional Tudor timber frame cottage with vertical tiling

## Why were the family selling their Tudor property?

This particular timber frame house is sadly a probate property that was being sold by the family of the former owner. The house had been a family home for many years and so it was a very hard and sad decision to have to sell it.

Unfortunately as this is a very old property there have been a few difficulties in selling the property. Another Surveyor linked to a mortgage company, who was not very experienced in dealing with historic buildings, had already carried out a survey and had basically seen characteristics of the property as problems and had advised some prospective buyers against the purchase and so they pulled out of the sale.

This was very upsetting for the family who knew there were no major problems with the property especially as they had a retired Building Surveyor in the family. The family then decided to have an Independent Building Survey carried out to help with any future interest in the property.

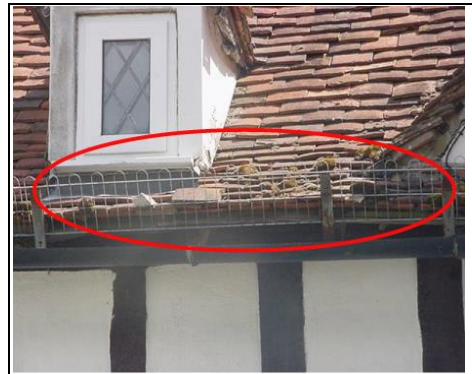

Old peg tiles that are likely to slide off the roof so a slate guard or in this case a tile guard has been used



Repairs have been wrongly made to this timber frame in cement or plastic wood instead of splicing with new timber



Old Tudor properties often have walls that are out of true or not straight. The level shows just how far the property is leaning. A survey will advise you if this is a problem or not

### Probate property Defined

This is where a property is passed to the family or beneficiaries of the deceased via an Executor named in the will as per their wishes. This legal process confirms that the will is valid.

## Our pre-sales building survey can help to sell the property

An Independent Building Surveyor is completely impartial and does not work for banks, building societies, or any form of mortgage lender. This pre – sales building survey that we carried out means that any problems or issues with the property will already have been found and the sellers can either decide to rectify some or all of these issues before the sale of the house or they can advertise the property with these problems and adjust the sale price accordingly.



Timber frame ceiling

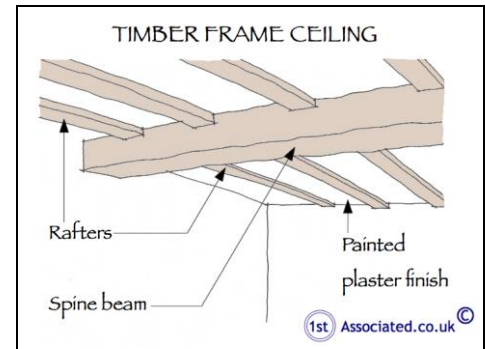

Timber frame ceiling

## Losing faith in the Estate Agent

The family that were selling this Tudor property had lost faith in their Estate Agent and asked us for advice on alternative ways to sell the property.

An Estate Agent is commissioned to sell the house, nothing more and nothing less. We advised our clients that it may be best to try other methods such as selling the house themselves as at the end of the day they are the only ones that have their true interest at heart.



Tudor property

## Selling the house on the internet

In this case the clients were really interested in the information we gave them about selling the property themselves on the internet as their Estate Agent had done such a bad job. There are various



internet companies that allow you to sell your property yourself with minimum costs.

1. The Little House Company UK
2. Tepilo
3. Sell Your Own Home UK
4. The House Sale UK

There are also companies that offer a quick sale. These companies will require a discount which can be considerably below the open market value. Here are a few such companies:-

1. A-Quick-Sale UK
2. Alliance Homebuyers UK
3. We Buy Any House
4. We Buy Any Home
5. National Homebuyers UK



Tudor property with old style diamond panel lead light in a cast iron window. This is one of the earliest windows outside of the church, royalty and other wealthy establishments

We also advised the family that sometimes just placing adverts in local shops to let local people know the house is up for sale and doing a leaflet drop can help to sell the property.



**You may find our surveying article on problems associated with timber framed properties and our other property articles helpful.**

<http://1stassociated.co.uk/tudor-era-problems.asp>

[http://1stassociated.co.uk/compare\\_surveys.asp](http://1stassociated.co.uk/compare_surveys.asp)

<http://1stassociated.co.uk/cracking-movement-info.asp>

<http://1stassociated.co.uk/flooding.asp>

## What do the circles and ovals mean in our reports?

The red ovals and circles are a system that we use within our structural surveys and building surveys to help explain to you or highlight problem areas or characteristics of a property such as a timber roof structure as in the photo.



Timber roof structure with ridge timber circled. This is cracking is it important?

## Our unique sketches to help you understand the survey

If the report, along with our photos, does not explain the problem or characteristics of a property enough then we also have a vast range of sketches that we have had commissioned exclusively for us that we can use in our reports.

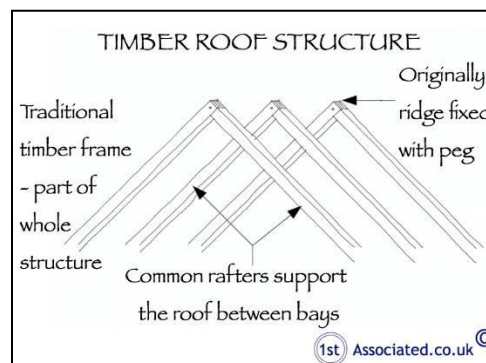

Timber roof structure

## Caveat Emptor

Caveat emptor means Buyer Beware and this is why, if you are considering buying a property, you need to have a building survey carried out to find out if there are any problems within the property that you need to be aware of. Often estate agents will not advise you of these.

If you are selling a house it can help to sell the property if you have had a Pre-Sales Survey carried out.



This Tudor cottage has a timber frame.

## **Independent Building Surveyors**

We are experienced independent building Surveyors who are knowledgeable in carrying out structural surveys on all types, styles and eras of buildings. If you are looking to buy or sell a Tudor property it makes sense to have a structural survey carried out by an Independent Surveyor. Phone us for a friendly chat on 0800 298 5424.

## **Compare our website and compare our surveys**

Please feel free to have a look at our website [1stAssociated.co.uk](http://1stAssociated.co.uk) to see for yourself the quality of our website, articles and our Building Survey reports. We pride ourselves on our professional standard and easy to read reports which we have been carrying out for many years on every age, type and style of property across the UK.

## **We can email you examples of our building surveys**

If you are thinking of buying a property and are interested in having a Structural Survey carried out or if you are trying to sell a property and would like a Pre-Sales Survey please call us on free phone us for a friendly chat on 0800 298 5424. We would be happy to email you several examples of our tailor made reports.

## **All rights reserved by 1stAssociated.co.uk**

All rights are reserved the contents of the website is not to be reproduced or transmitted in any form in whole or part without the express written permission of [www.1stAssociated.co.uk](http://www.1stAssociated.co.uk)